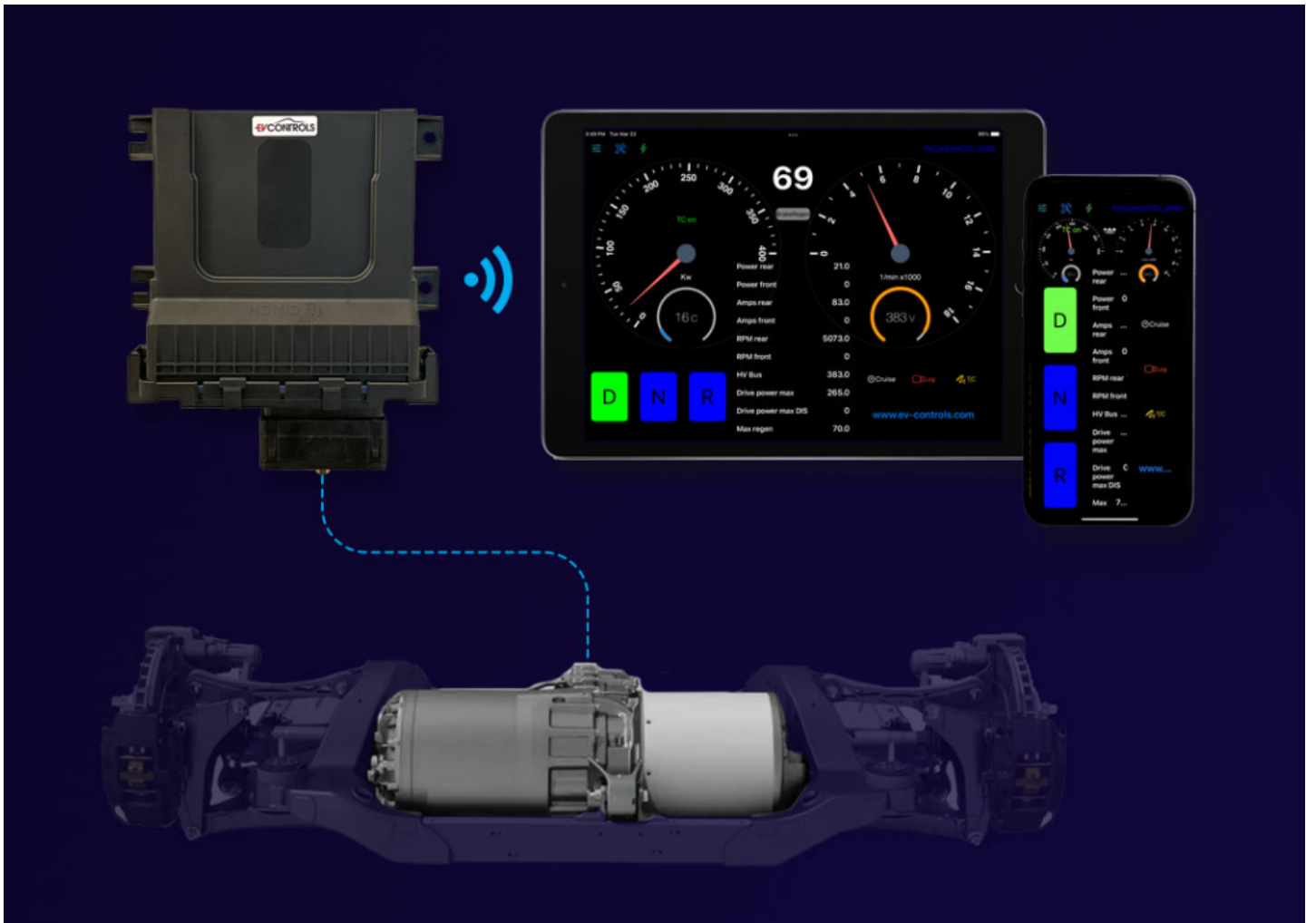

Table of Contents

1. EV-Controls T2C Manual V1.2	1
2. T2C initial setup and inverter flash procedure	2
3. Dash app features and screens	3
3.1. Main screen	3
3.2. Utilities screen	5
3.3. Settings screen	7
3.4. BMS screen	10
3.5. Traction control	12
3.6. Cruise control	13
3.7. Vehicle hold	14
3.8. Datalogging features	15
3.9. Charging mode	16
4. T2C outputs	17
5. T2C inputs	18
6. Wiring Diagrams	19
6.1. General guidelines for installation	19
6.2. T2-C Controller Pinout	21
6.3. Model S/X Large drive unit	22
6.4. Model S/X small drive unit	23
6.5. Model 3/Y drive unit	24
6.6. HV wiring	25
6.7. GNSS Traction control module	25
6.8. Tesla Model S Inverter Pinout	26
6.9. Tesla Small "D" Motor Pinout	27
6.10. Model 3/Y HV connector	28
6.11. Model 3/Y Battery controller	29
7. Troubleshooting	30
8. GNSS traction control module	32
9. CAN control of functions	34

EV Controls Manual V1.3



Initial setup

In order for the T2C to control your drive unit properly, the firmware on the drive unit must be the correct version. This generally means the inverter will need to be reflashed. Once you have wired the T2C and inverter according to the wiring diagrams elsewhere in this guide, you will need to get the inverter info and send it to us so we can verify it, and assist with flashing the inverter if required. The flash procedure is simple but varies depending on the drive unit type and firmware currently on the drive unit. Please do not contact us about reflashing until you have completely wired up the inverter and high voltage as per the wiring diagrams.

On the Model 3/Y drive units, this includes the oil pump, which must be connected and powered.

Once you have done this, start the app, and navigate to the utilities screen using the icons at the top left.

Click "show info", and send a screenshot of the information that comes up to support@ev-controls.com along with your order number.

If the information shows all blank info or zeroes, there are a couple possible causes.

1) You have a Model 3/Y drive unit and the controller has Model S/X firmware on it. If this is the case, e-mail support@ev-controls.com and we will assist.

2) You have a problem with the CAN communications to your inverter or a 12V supply problem. If this is the case you will need to sort this out first.

We will reply by e-mail with the next steps required for your specific hardware. Never try flashing the inverter yourself without specific instruction to do so from ev-controls support, this will not work and likely cause other problems and delays.

We will only flash one inverter per controller sold.

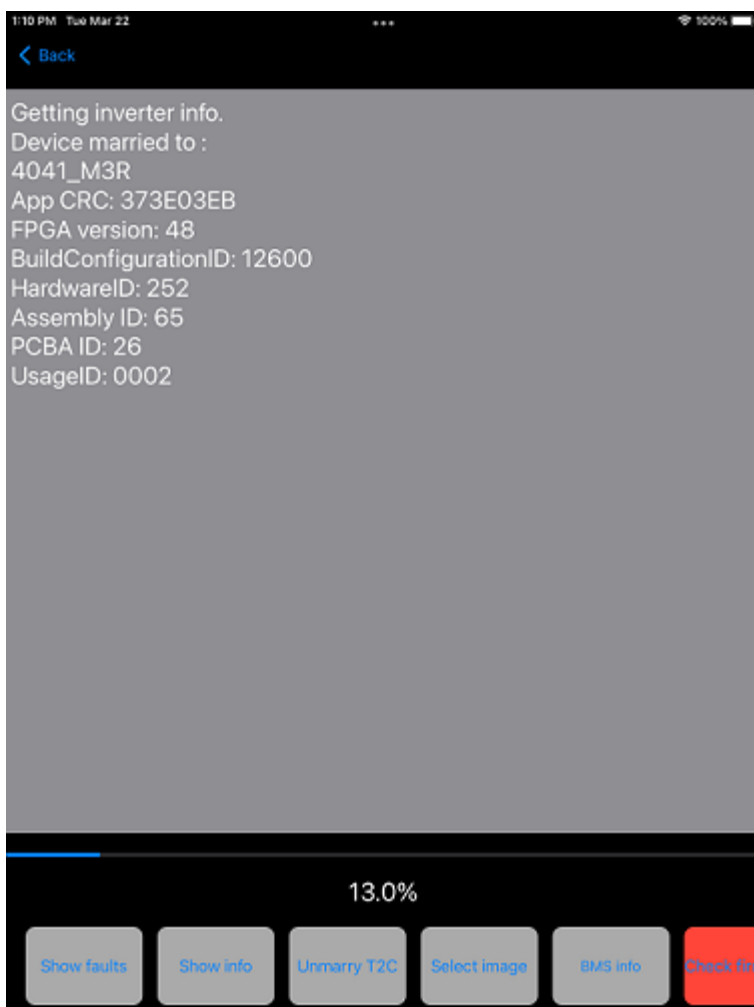

Dash app

The [EV-controls dash app](#) is available for free in the apple app store.

This provides the user with a very versatile dashboard they can use in their vehicle, and also has a variety of other functionality that is outlined elsewhere in this manual.

We find that an iPad mini makes great display that will fit in almost any vehicle. See [this video](#) on our youtube channel for instructions on how to have your iPad and dash app power on and off with the ignition key using an automation. In our opinion this solution outperforms any other options for an in vehicle display, in terms of functionality, reliability and appearance. Plus new features will be added over time and made available in the app store. We also offer a version for the iPhone now, so users can quickly access settings and other features from their phone.

The **main screen** will be the default screen and functions as a dashboard.

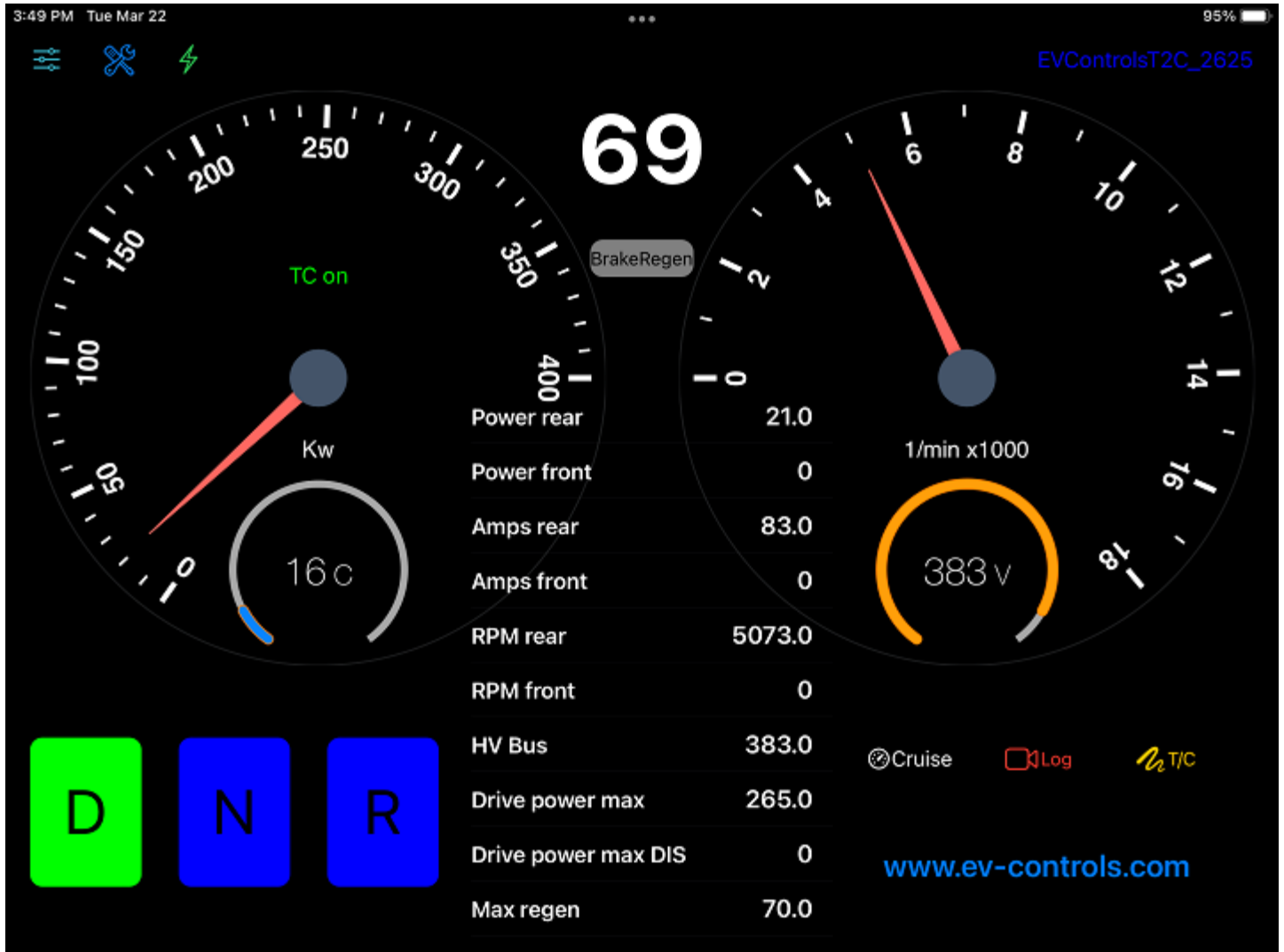

At the top left are navigation icons that allow you to access the settings and utilities screens, and charging mode.

At the top right is the T2C connection status , it will either display "Not connected" or the unique ID of the T2C controller it is currently connected to.

On the left is a power gauge that displays drive power in kW. It also has indicators for traction control status, and vehicle hold status.

At the bottom of this gauge is an inverter temperature display.

On the right is a motor RPM gauge. It also has indicators for cruise control, and logging status that will come on when either of these features are active. At the bottom of this gauge, battery pack voltage is displayed.

Top center is a vehicle speed display (speedometer).

Below that is a brake/regen indicator that will turn red when the brake light output is active. This will occur when the brake pedal is depressed, or when the regen is slowing the vehicle enough that brake lights should be illuminated. You can use this indicator to confirm your brake switch is functioning properly. Tapping this indicator will also return the T2C to driving mode if it is in charging mode.

Under the brake/regen indicator in the center is a BMS warning indicator that will normally be off.

below this, in the center, is a scroll view of all the data coming back from the T2C. This data can be datalogged using the logging features.

At the bottom left are shift buttons that also display the current gear, turning green when that gear is engaged. You cannot shift into drive or reverse from neutral unless the brake is depressed.

At the bottom on the right are buttons for cruise control, datalogging and traction control.

tapping the cruise button engages the cruise control. To disengage cruise control, tap the brake pedal.

Tapping the Log button starts the datalogger and logs data to a .csv file. Tap the log button again to stop the logger.

Tapping the T/C button disables and enables the traction control if it is available.

Utilities screen

This screen will give you access to various utilities and functions used for setup and troubleshooting.

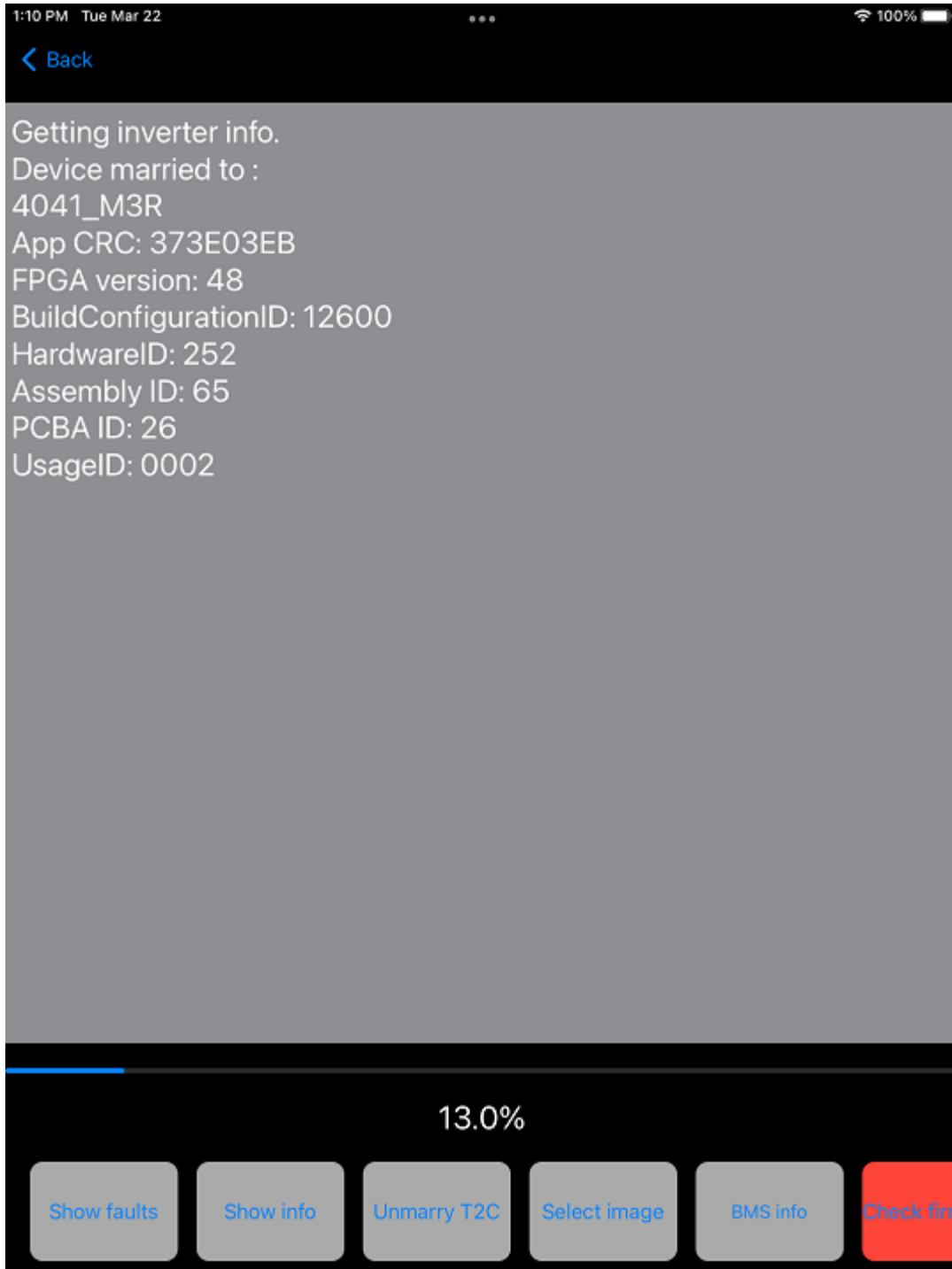

Show faults

You can read out fault codes by clicking "show faults" under the utilities screen. This feature is helpful for troubleshooting.

The fault codes themselves have descriptive names that will help you pinpoint the source of problems. We do not have extra information on the fault codes beyond what you see in the fault code text itself.

Show info

Tapping this button while connected will show the current T2C firmware version, the unique ID from the T2C that that app is currently married to (if it is married to one), and a list of information used to ID the drive inverter hardware and software versions.

This is the button we will ask you to use during the initial firmare setup process for your T2C.

Unmarry T2C

when you first power on your T2C and start the app, you should be presented with an option to "Marry" the app to that particular T2C.

Once you tap "Marry", the app will remember that particular T2C controller's unique ID, and will not look for or detect other T2C controllers. This is so that you do not connect to any other T2C controllers that might be within range. If you want the app to detect other T2C controllers within range, tap the "Unmarry T2C" button in the utilities screen. This will cause the app to forget the controller it was married to, and search for other controllers again.

Select image

We added the ability for a user to select a background image that will be shown briefly on power up when the T2C connects. This allows you to customize your dashboard with an image or logo of your choice. When the T2C powers on and is detected by the app, the image will be displayed and fade out during the gauge sweep sequence.

BMS info

We have added some BMS support features to the T2C software. The simplest and most versatile feature is a "BMS warning" light that will come on when the SPARE 1 input is grounded. This will allow you to be notified of a BMS fault on that dash app, and will be compatible with any BMS you can configure to ground this input when it detects a fault condition.

We also have added CAN bus support for the Dilithium BMS. If you connect the Dilithium CAN output to CAN 1, set the baud rate to 500kbs, and configure the termination resistor in the BMS to disabled, the T2C should read out and display cell voltages (up to 96), fault status, highest and lowest cells, and illuminate the "BMS warning" light in the dash app when the BMS detects a fault. This is accessible under the utilities screen, if you tap "BMS info".

Check firmware

Clicking this button will get the current T2C firmware version on your controller, and compares it to the latest version available on our servers. If there is a newer version available, you will be presented with the option to upgrade. Obviously never click this button unless you are parked, your iOS device is connected to the internet, and you are prepared to do a firmware update.

Change config, Flash DI/ PM/ DIS/ PMS/ FPGA

These buttons are only to be used if we directly instruct you to, and are for initial setup of your T2C and inverter. Using them under any other conditions will result in a best case scenario of nothing happening, or serious problems like a non functional inverter or T2C. Never tap these unless we specifically tell you to.

BMS Demo

This shows a demo of the BMS display screen that is currently only available for a properly configured the Dilithium BMS.

Under the **settings screen**, you can set various parameters and write the settings to the T2C to make them active.

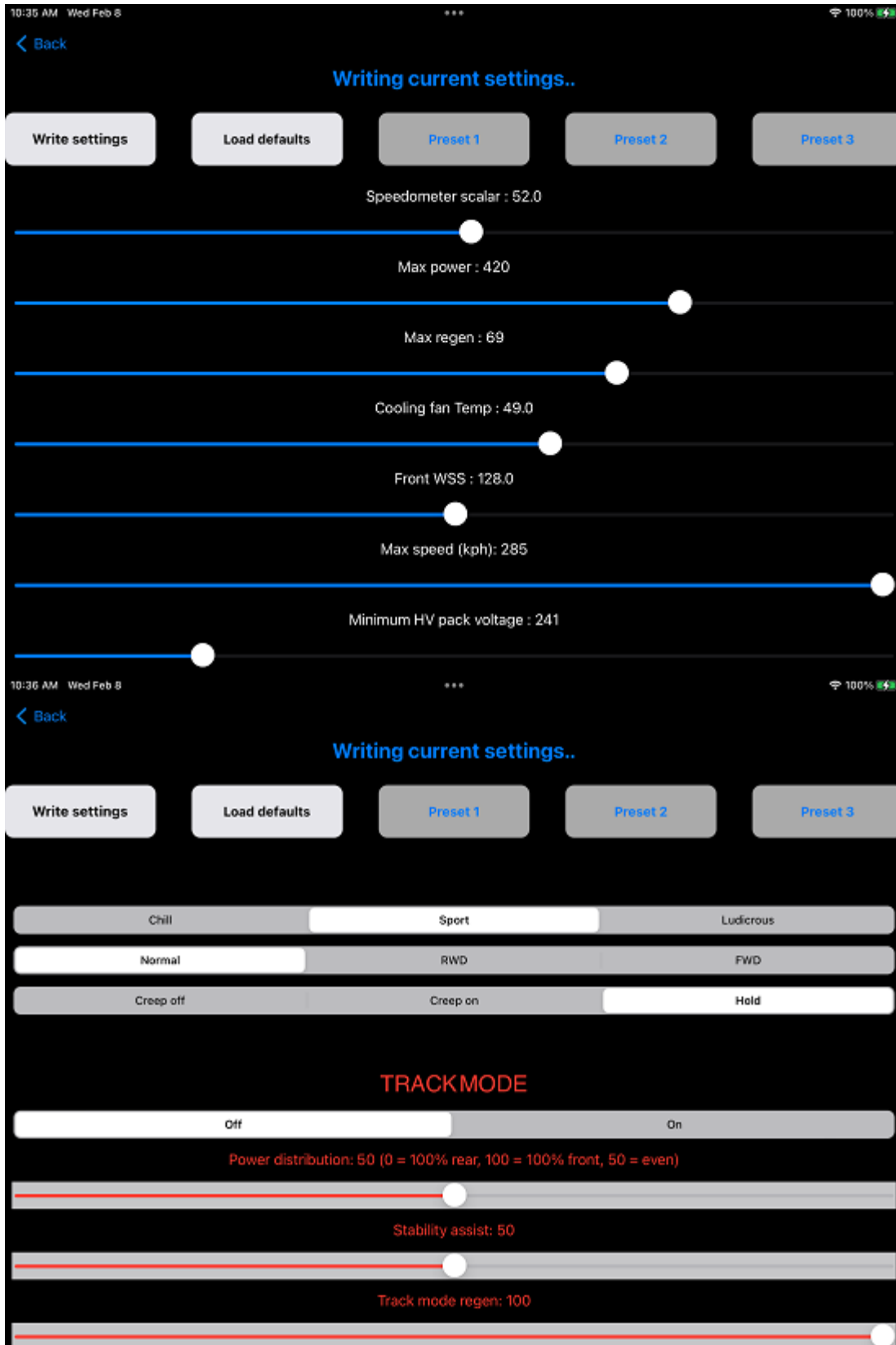

Speed scalar

This should be set to a value that makes the speed readout in the top center of the main screen read accurately. Increase or decrease this value until the speed readout on the main display matches the speed displayed on a GPS you use for

reference. This value will be stored in the app so you should only need to set it once per iOS device used. It is used to account for differences in drive wheel diameter.

Max power

This is the max power the drive will develop, in kW, when the accelerator is fully depressed. This can be limited of course by other factors like battery capability and voltage sag, and the drive unit's maximum power output capability.

Max regen

This is the same as the above max power setting, but applies under regen conditions. Set it according to your needs and the battery pack's ability to absorb charging current.

Cooling fan temp

This is the value (in degrees C) at which the cooling fan output (E2) will be energized, and is generally used to trigger a cooling fan on the inverter cooling system radiator (through a relay of course). The output will turn off again once the inverter temp decreases to 2 degrees below the value you have set.

Front WSS

This value is used for traction control. In the case of the new GPS based traction control released in 2022, it should be set so that the displayed "TC slip measured" value is as close to zero as possible when driving in a straight line under no wheelspin conditions. It is used to account for differences in drive wheel diameter. On dual motor applications it is used to adjust for differences in front and rear drive wheel diameters. A good starting point is 128, which translates to a multiplier of 1 (no correction).

Max speed

Self explanatory, this is a maximum speed limiter.

Write settings

At the top of the settings screen, you have a button that will write the current settings to the T2C (all but the wheel speed scalar setting, which is stored in the app itself). The settings will then stay stored in the T2C, and will be read back out and displayed when you navigate to the settings screen next time.

Preset buttons

We have also added 3 "**Preset**" buttons at the top, which allow you to store and quickly change between settings profiles you may want to choose between on a regular basis. To store a preset, select the values you want to store using the sliders, then press and hold the preset button for a few seconds. The label at the top should say "Preset XX saved" once that profile has been saved. You can do this for all 3 presets. Then, when you tap the preset button next time, that settings profile will be loaded and written to the T2C.

Minimum pack voltage

This limit will be the lowest voltage value the inverter will draw the pack down to under load. Tesla use a value of 241V for their 96S packs.

You can adjust this to suit the minimum voltage you want to use for your battery pack if you want to. This value must account for sag under load.

We cannot provide this value for you, so please do not contact us about this.

Maximum pack voltage

This limit will be the highest voltage value the inverter will regen up to while decelerating. Tesla use a value of 401V for their 96S packs.

You can adjust this to suit the maximum voltage you want to use for your battery pack if you want to. This setting is not a complete substitute for regen derating by the BMS.

We cannot provide this value for you, so please do not contact us about this. If you want to prevent the inverter from charging the battery pack when it is close to fully charged, you might want to set it 10% lower than your fully charged pack voltage.

CHILL/SPORT/LUDICROUS settings

This will toggle between the different power levels your drive unit(s) supports. This varies depending on the drive unit, powertrain type and hardware version.

NORMAL/RWD/FWD

This will switch between AWD, RWD and FWD on dual motor powertrains that support the feature.

Once you set the powertrain to RWD or FWD you generally need to power it off and on again to go back to default settings.

CREEP OFF/ON/ HOLD

Enables and disables creep mode on all supported powertrains, and enables hold mode on PMSR type powertrains (Model 3 and Y).

TRACK MODE

These settings allow you to adjust the track mode features available with performance Model 3 powertrains.

The vehicle must be in neutral and you must write the settings to turn track mode on.

You must click write settings to make changes to the other parameters before they take effect.

The **BMS screen** will give you a graphic display of cell voltages, highlighting the highest and lowest in read and green, if you have a properly configured Dilithium BMS connected to CAN 1.

Dilithium changed the CAN protocol for their latest BMS offering to a format that conflicts with the CAN ID's the Tesla inverter uses, so the new systems are not compatible.

We are currently testing support for the Model 3 BMS. We do not directly support any other BMS systems.

See the CAN control functions elsewhere in this manual for details on how users can configure other BMS systems to derate power and regen over CAN.

We cannot assist with programming BMS systems beyond providing the format the T2C requires for these messages.

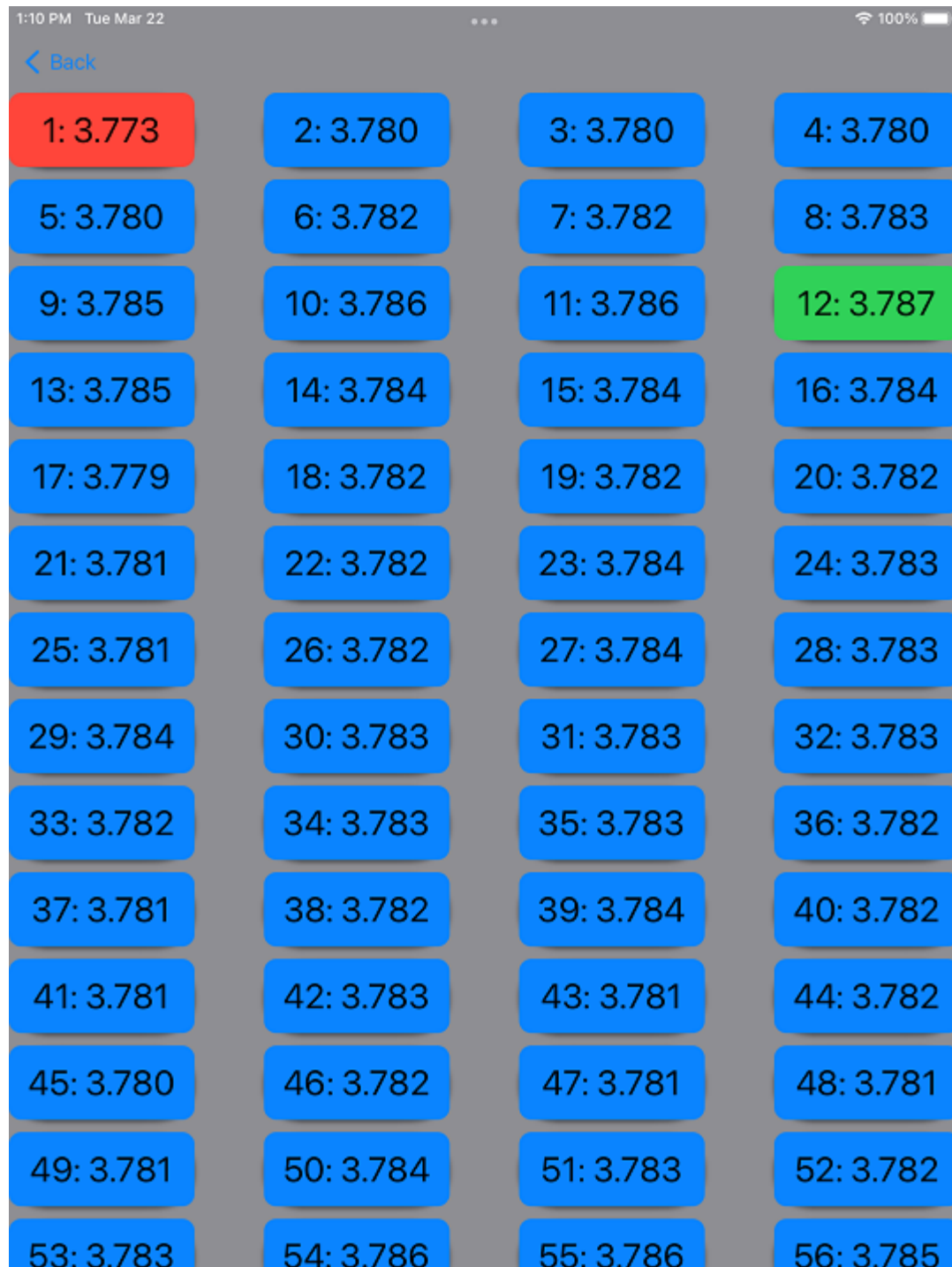

Tesla Model 3 BMS screen that will be available in the near future;

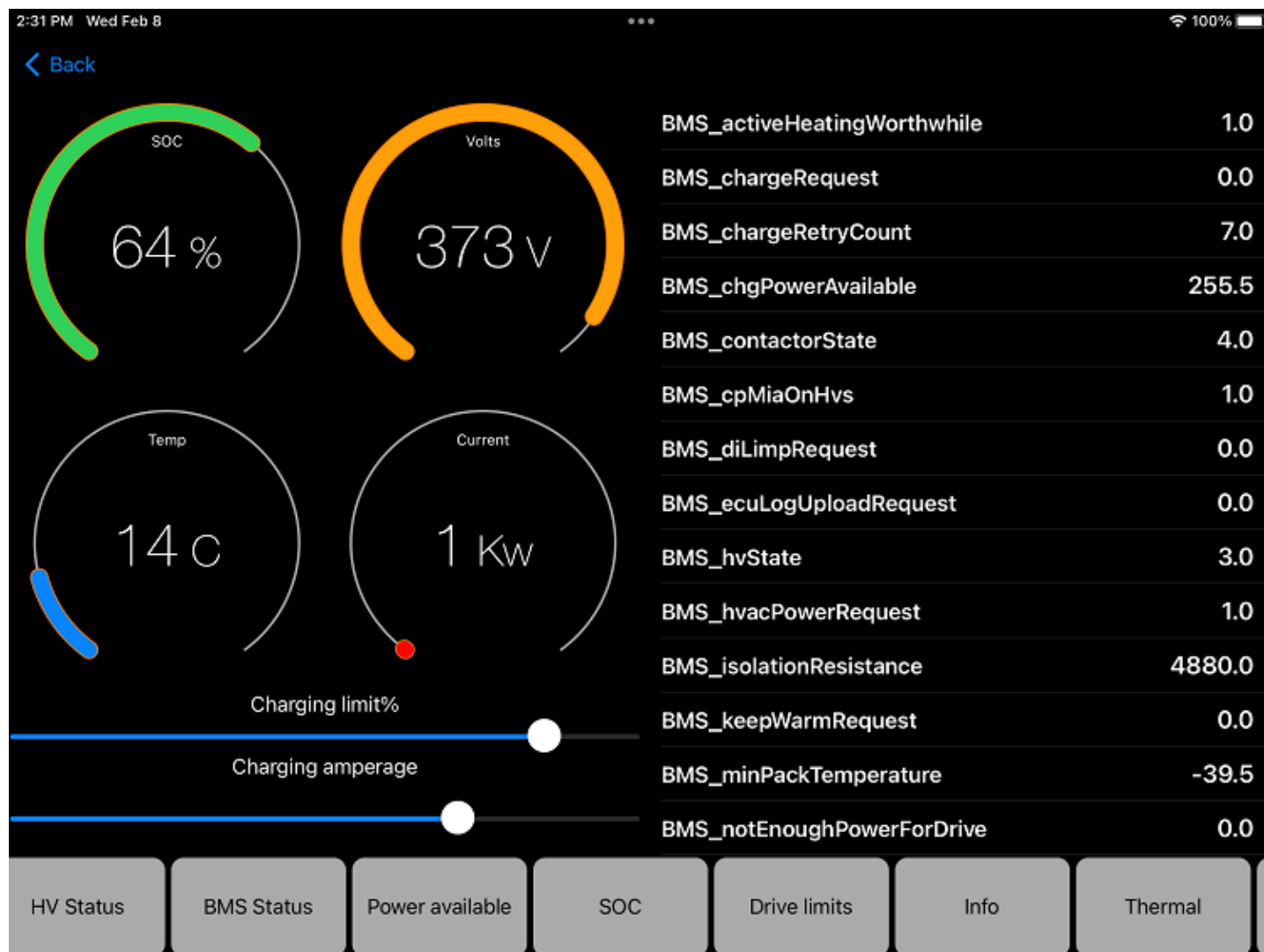

Traction control

We are releasing traction control features for the T2C in early 2022. Our traction control system uses a high resolution GNSS module we developed, along with our software, to modulate torque under acceleration and regen conditions and maintain drive wheel traction at the limit of what is available.

To use the traction control features, you need to install the EV-controls GNSS module and connect it to the CAN bus (CAN 1), 12v power and ground. The T2C software monitors data coming from the module, and when a valid signal is available, traction control will be enabled. You can monitor the status of the traction control in the dash app. An icon at the top of the left power gauge will either display "no TC", "TC on", or "TC active" when the system is limiting torque for longer periods.

You can monitor the satellites available to the GNSS module, and the difference in speed between the driven wheels and actual vehicle speed (kph) in the center information scroll view. These values are near the bottom, so scroll down to see them. You can also use the logging features to monitor these parameters.

You must adjust the "front wheel speed scalar" value under the T2C settings so that the "TC slip measured" parameter is as close as possible to zero while driving straight at low power. The value is high resolution and measures in hundredths of a kph, so it is normal for it to vary slightly above and below zero under these conditions. You can also disable/enable the traction control by using the TC icon in the bottom right of the screen. This can be useful to satisfy juvenile tendencies that may present themselves, and perform emergency maneuvers (ie. burnouts and doughnuts).

Traction control will never be enabled unless a valid GPS signal is available, so you can disable traction control entirely by simply switching off the GNSS module.

Cruise control

We have added cruise control features for most applications recently. To engage cruise control, tap the "Cruise" icon at the bottom right of the main screen. The current speed should be maintained until you tap the brake pedal. you can also engage cruise by grounding the "Spare 2" input on the T2C for customers who want to use a dedicated button. When the cruise control is active, the blue "Cruise" icon should be visible near the top of the RPM gauge.

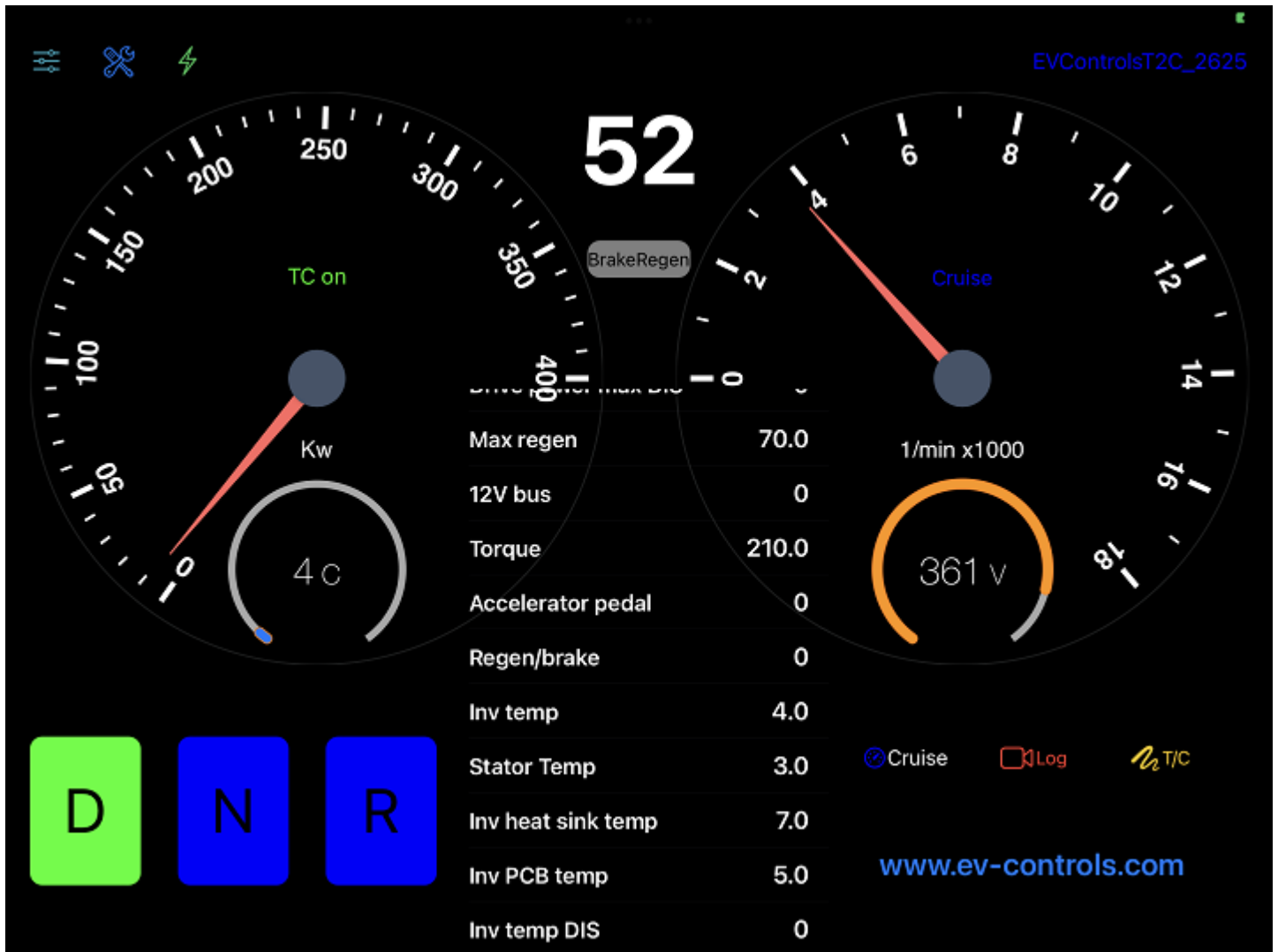

Vehicle hold

On Model 3/Y drive units, the vehicle hold feature should be functional under normal conditions. This will help hold the vehicle stationary when at a stop, without the need to hold the brake pedal down. When the vehicle hold is active, a red "HOLD" icon will be visible near the top of the power gauge on the left.



Datalogging features

The T2C dash app allows you to log data to .csv files to record data during acceleration runs or for other purposes. This can be very useful to monitor things like amperage, battery voltage sag under peak power, or wheel slip under acceleration. To log to a file, just tap the logging icon at the bottom right of the main screen. The "logging" icon will appear at the top of the RPM gauge, and the T2C dash app will record to a .csv file until you tap the logging icon again. Once you tap the logging icon a second time, you will be given options to send the .csv log file you have created by e-mail, text etc..

Timestamp																													
A	B	C	D	E	F	G	H	I	J	K	L	M	N	O	P	Q	R	S	T	U	V	W	X	Y	Z	AA	AB	AC	AD
1	Timestamp	Power res	Power fro	Amps rear	Amps for	RPM rear	RPM front	HV Bus	Drive pow	Drive pow	Max rege	12V bus	Torque	Accelerat	Regen/bri	Inv temp	Stator Ten	Inv heat si	Inv PCB te	Inv temp I	Stator Ten	Inv heat si	Inv PCB te	Brake swi	Current g	TC_Slip	MGPS sats	Peak pow	Peak amps
2	02:50.4	0	0	3	0	4	0	392	404	0	70	0	0	0	0	24	34	31	26	0	0	0	0	8	4	4	13	239	742
3	02:50.6	0	0	2	0	9	0	392	404	0	70	0	-5	0	0	24	34	31	26	0	0	0	0	8	4	12	13	239	742
4	02:50.9	0	0	2	0	3	0	392	404	0	70	0	-13	0	0	24	34	31	26	0	0	0	0	8	4	4	13	239	742
5	02:51.0	0	0	6	0	0	0	392	404	0	70	0	-39	0	0	24	34	31	26	0	0	0	0	0	4	0	13	239	742
6	02:51.2	0	0	8	0	2	0	392	404	0	70	0	-29	0	0	24	34	31	26	0	0	0	0	0	4	0	13	239	742
7	02:51.5	9	0	52	0	336	0	391	404	0	70	0	1272	85	0	24	34	31	26	0	0	0	0	0	4	463	13	239	742
8	02:51.7	10	0	291	0	216	0	390	404	0	70	0	2280	100	0	24	34	31	26	0	0	0	0	0	4	221	13	239	742
9	02:51.8	14	0	387	0	333	0	389	404	0	70	0	2480	100	0	24	34	31	26	0	0	0	0	0	4	175	13	239	742
10	02:52.1	29	0	468	0	541	0	387	404	0	70	0	2808	100	0	24	34	31	26	0	0	0	0	0	4	229	13	239	742
11	02:52.3	52	0	598	0	816	0	383	404	0	70	0	3636	100	0	24	34	31	26	0	0	0	0	0	4	339	13	239	742
12	02:52.4	68	0	755	0	1053	0	378	404	0	70	0	3936	100	0	24	34	31	27	0	0	0	0	0	4	306	13	239	742
13	02:52.7	83	0	781	0	1321	0	376	404	0	70	0	3724	100	0	24	34	31	27	0	0	0	0	0	4	297	13	239	755
14	02:52.9	88	0	797	0	1635	0	372	404	0	70	0	3946	100	0	24	34	31	27	0	0	0	0	0	4	352	13	239	781
15	02:53.0	113	0	821	0	1993	0	368	404	0	70	0	3960	100	0	24	34	31	27	0	0	0	0	0	4	451	13	239	797
16	02:53.3	121	0	822	0	2256	0	366	404	0	70	0	3802	100	0	24	34	31	27	0	0	0	0	0	4	406	13	239	821
17	02:53.5	135	0	818	0	2576	0	363	404	0	70	0	3742	100	0	24	34	31	34	0	0	0	0	0	4	469	13	239	822
18	02:53.7	147	0	810	0	2850	0	360	404	0	70	0	3916	100	0	24	34	31	34	0	0	0	0	0	4	452	13	239	822
19	02:53.9	155	0	807	0	3135	0	358	404	0	70	0	3878	100	0	24	34	31	34	0	0	0	0	0	4	467	13	239	822
20	02:54.1	180	0	809	0	3435	0	354	404	0	70	0	3704	100	0	24	34	31	34	0	0	0	0	0	4	502	13	239	822
21	02:54.3	184	0	807	0	3664	0	352	404	0	70	0	3848	100	0	24	34	31	34	0	0	0	0	0	4	441	13	239	822
22	02:54.5	204	0	810	0	4004	0	349	404	0	70	0	3914	100	0	24	34	31	42	0	0	0	0	0	4	552	13	239	822
23	02:54.7	211	0	805	0	4274	0	347	404	0	70	0	3856	100	0	24	34	31	42	0	0	0	0	0	4	527	14	239	822
24	02:54.9	219	0	791	0	4543	0	346	404	0	70	0	3780	100	0	24	34	31	42	0	0	0	0	0	4	538	14	239	822
25	02:55.1	247	0	790	0	4831	0	343	404	0	70	0	3660	100	0	24	34	31	42	0	0	0	0	0	4	478	14	239	822
26	02:55.3	243	0	782	0	5104	0	342	404	0	70	0	3778	100	0	24	34	31	42	0	0	0	0	0	4	524	14	247	822
27	02:55.5	259	0	775	0	5357	0	341	404	0	70	0	3674	100	0	24	35	31	48	0	0	0	0	0	4	511	14	247	822
28	02:55.7	253	0	781	0	5567	0	339	388	0	70	0	3524	100	0	24	35	31	48	0	0	0	0	0	4	454	14	259	822
29	02:55.9	249	0	753	0	5812	0	339	369	0	70	0	3578	100	0	24	35	31	48	0	0	0	0	0	4	460	14	259	822
30	02:56.1	257	0	731	0	6020	0	340	353	0	70	0	3420	100	0	24	35	31	48	0	0	0	0	0	4	431	14	259	822
31	02:56.3	249	0	703	0	6264	0	340	339	0	70	0	3264	100	0	24	35	31	48	0	0	0	0	0	4	469	14	259	822
32	02:56.5	243	0	686	0	6457	0	340	325	0	70	0	3144	100	0	25	35	31	50	0	0	0	0	0	4	467	14	259	822
33	02:56.7	246	0	661	0	6620	0	341	312	0	70	0	2982	100	0	25	35	31	50	0	0	0	0	0	4	426	14	259	822
34	02:56.9	249	0	654	0	6798	0	341	301	0	70	0	2934	100	0	25	35	31	50	0	0	0	0	0	4	416	14	259	822

Charging mode

We use the Elcon 6600w 500kbs CAN controlled charger in several of our test vehicles, and have added CAN control capabilities for it to the T2C and app. If you are using the same model charger in your project, you should be able to use these capabilities if you choose to.

Clicking the lightning bolt icon in the top left of the main screen will put the T2C and app in charging mode.

In this mode, the contactors will open, and the pin B1 "charger" output will be powered with 12v. you can use this output to turn the charger on and close a charging contactor if you are using one.

The display will change to show charging current and HV battery voltage. You can set charge current and charging end voltage using the sliders on the screen. Clicking the "drive/regen" button between the main gauges will switch back into driving mode.

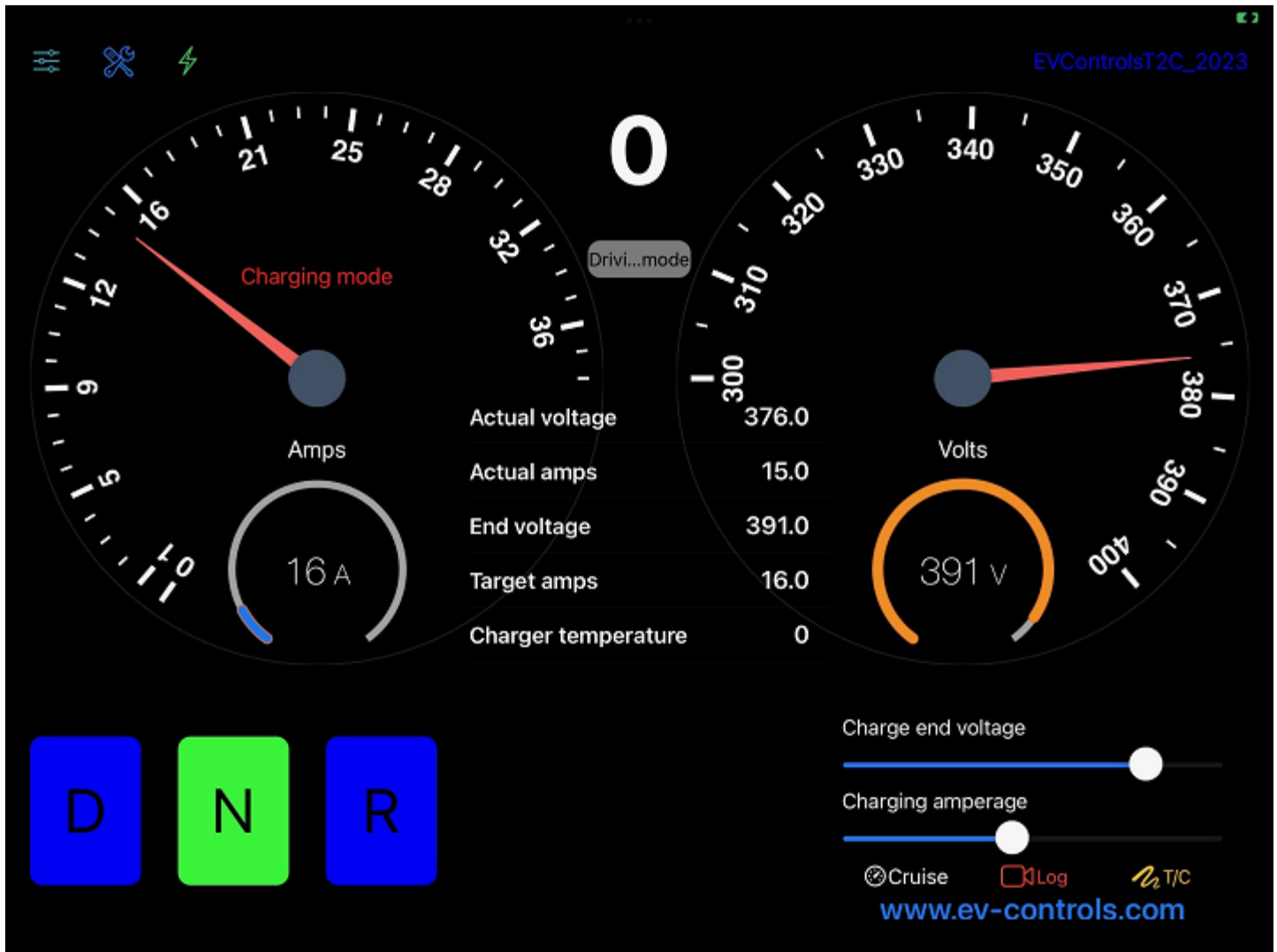

T2C outputs

The D/N/R indicator light, brake/regen light, reverse light and spare relay outputs are 12v outputs, and can drive low current draw indicator lamps directly. So are the positive and negative contactor, precharge relay and charger outputs. The cooling fan output is a 12v output but should drive an external relay in every case because of the high current draw.

The total current draw of all outputs should be kept under 8 amps, and should be no more than 4 amps for any single output.

12vBank1 supplies the following outputs with 12v;

[Positive contactor, negative contactor, precharge relay, Reverse lights, Spare relay bank 1]

12VBank2 supplies the following outputs with 12v;

[Charger output, Brake/regen lights, Cooling fan, Inverter 12v power, Spare relay bank 2]

T2C inputs

The current firmware requires momentary ground signals for the shift buttons, regen disable and spare (BMS warning and cruise switch) inputs. Current firmware allows these inputs to be held to ground if you want to use a shift selector that operates this way. With earlier firmware, holding them to ground can cause the T2C to be unresponsive on boot up.

Wiring Guidelines

- The following diagrams use Tesla color codes where possible, but these vary, so use pin numbers for the most accurate reference. This assumes that you will be using Tesla connectors for:
 - The drive inverter
 - Accelerator pedal
 - Brake switch
- The wiring diagrams show all connections, but you will not need to wire things like the resolver etc.. if you use the Tesla motor harness.
- The controller is equipped with the female side of a multi pin connector
- Your purchase includes a matching male side for the connector and required crimp connectors
- Connection details for the connector are included in the controller pinout diagram
- You must observe the fusing information provided in the included drive inverter diagram failure to do so may result in controller damage
- All CAN communication wiring must be twisted pairs
- Can communication wiring must be located as far as possible from high voltage wiring to prevent CAN communication interference
- It is recommended that you begin your project by drawing a color coded wiring diagram for your completed project

What you must provide

This guide is based on the assumption that you will have the following components in your possession

- Suitable drive unit (please email our support department to verify suitability)
- Drive unit wiring harness including inverter connector and shielded encoder harness with connector
- Tesla accelerator pedal with connector and a portion of the associated harness
- Brake switch with connector and a portion of the associated harness
- All associated wiring, fuses, contactors and switches
- A 12volt power source



ModICE WIRING HARNESS CONNECTOR

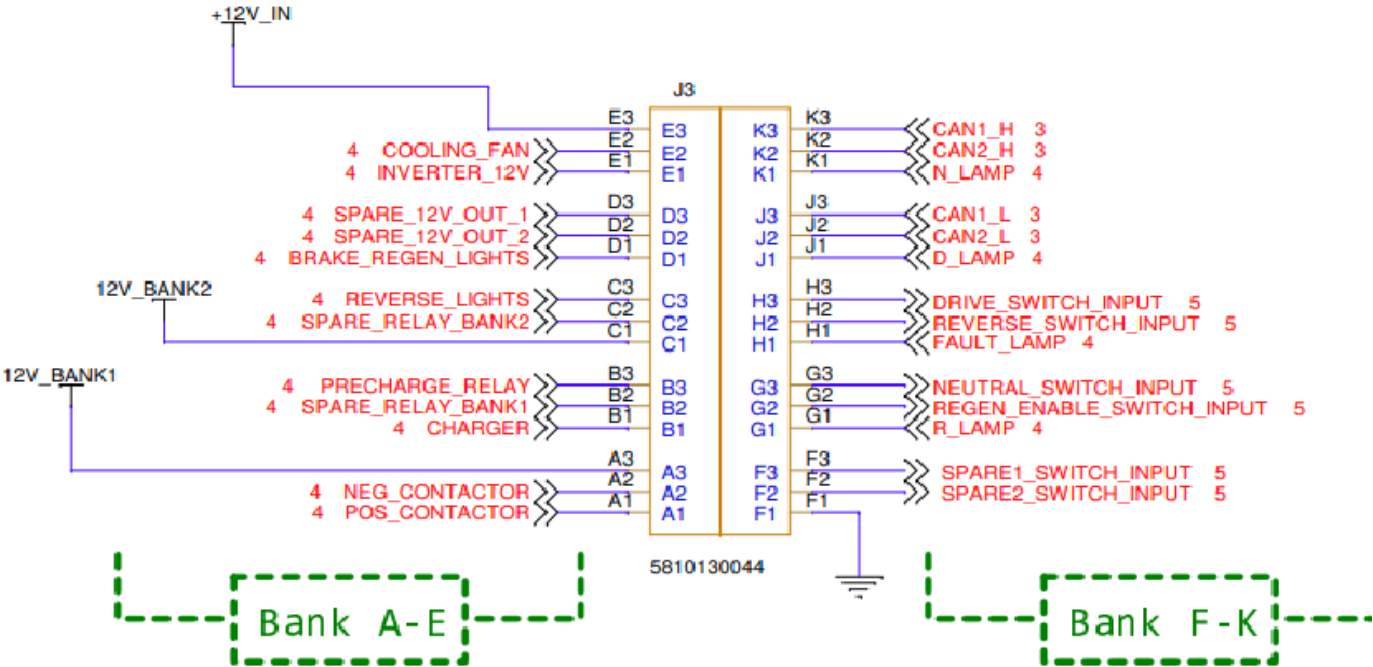

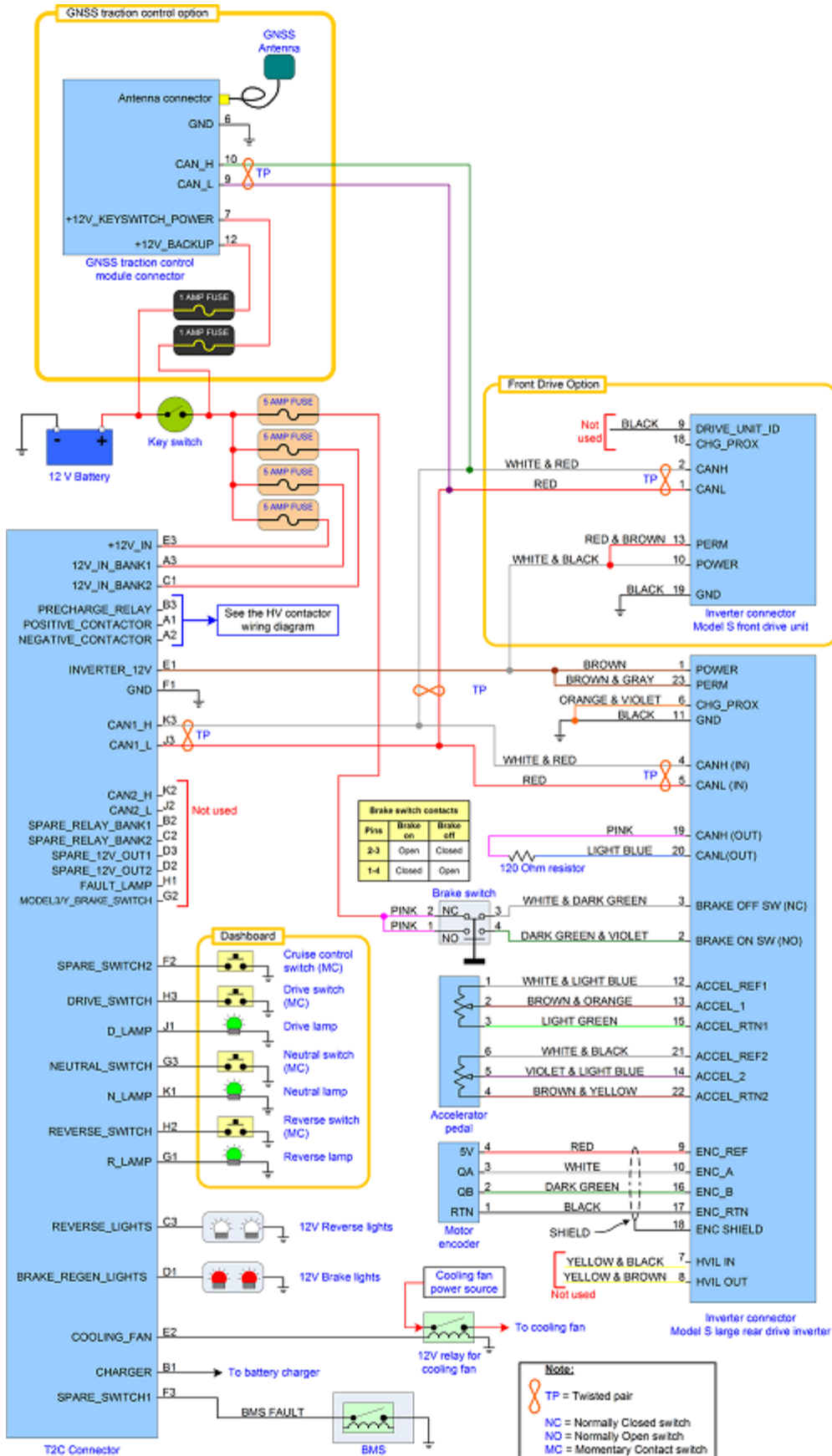

Wiring diagram: Model S with large rear inverter

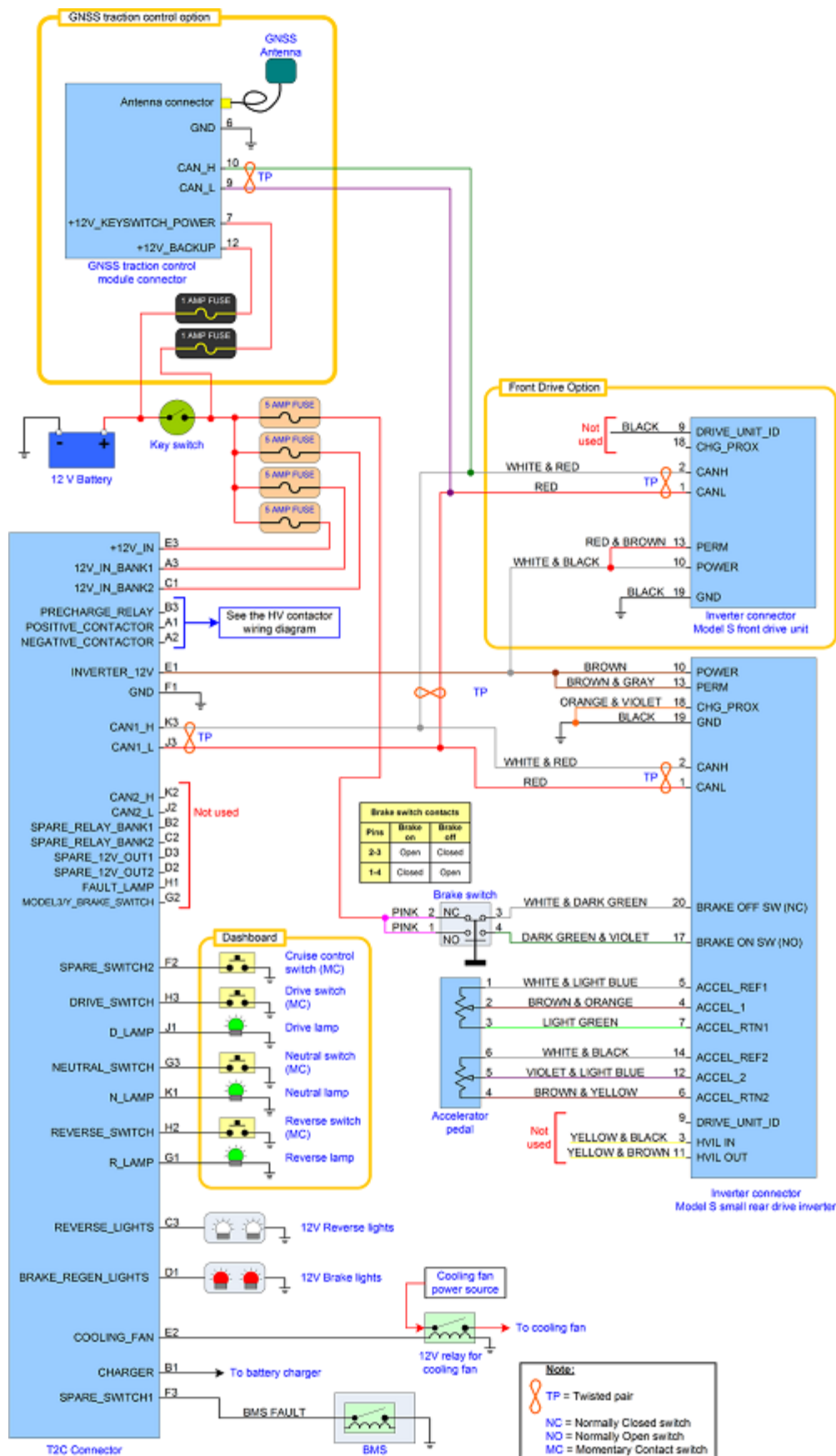

Wiring diagram: Model S with small rear drive inverter

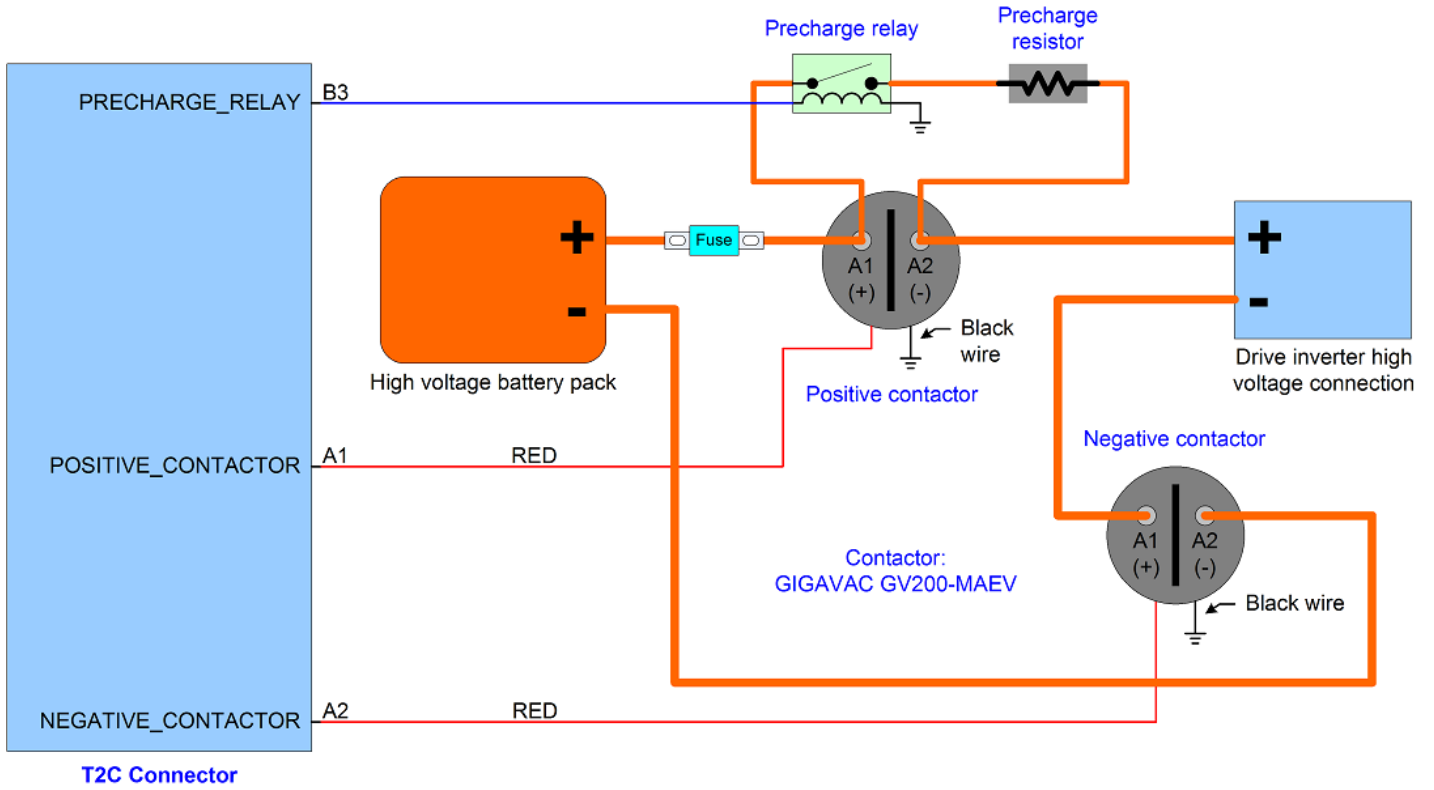

Wiring diagram: high voltage contactors

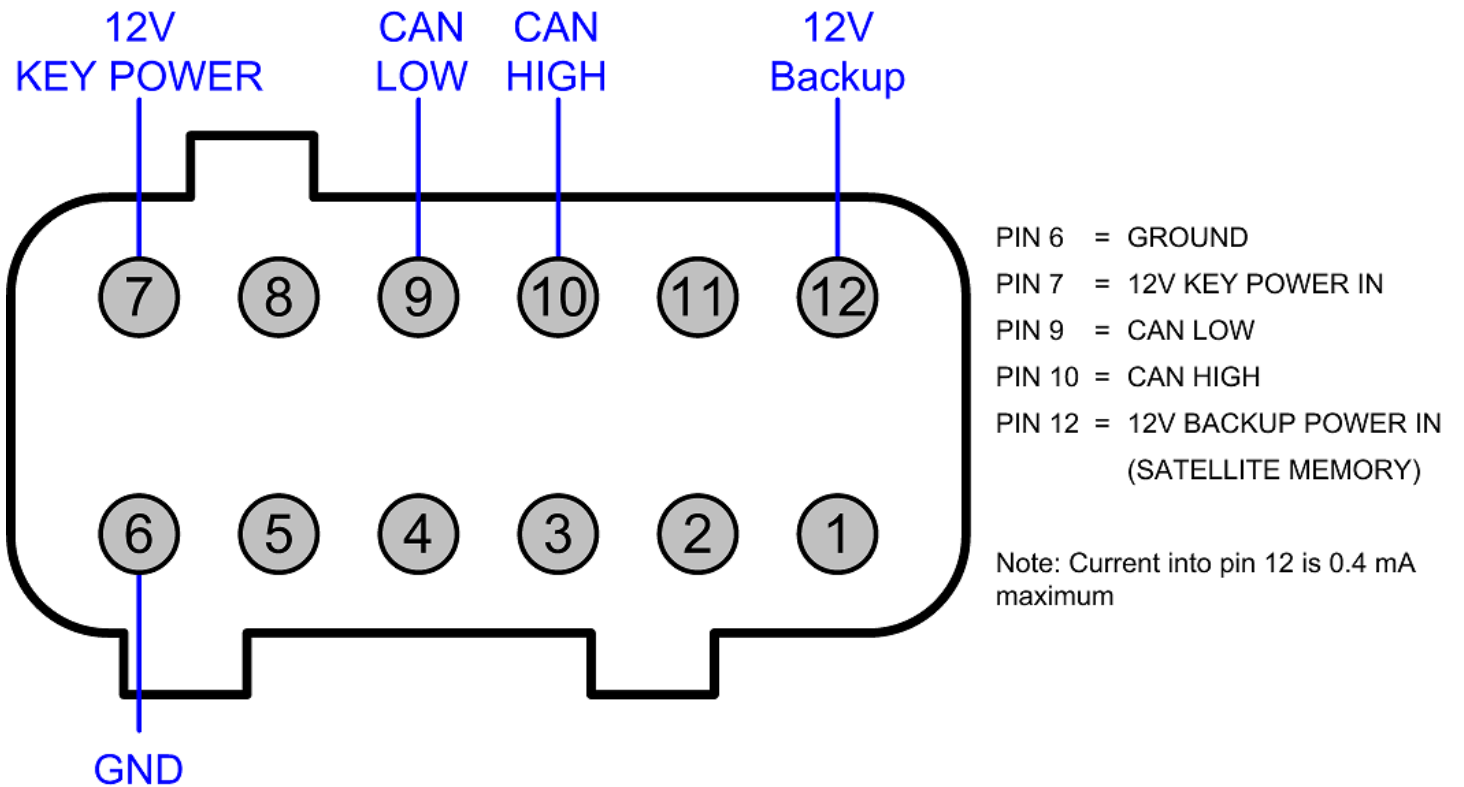

GNSS Traction control module pinout

Drive inverter connector (Not Supplied)

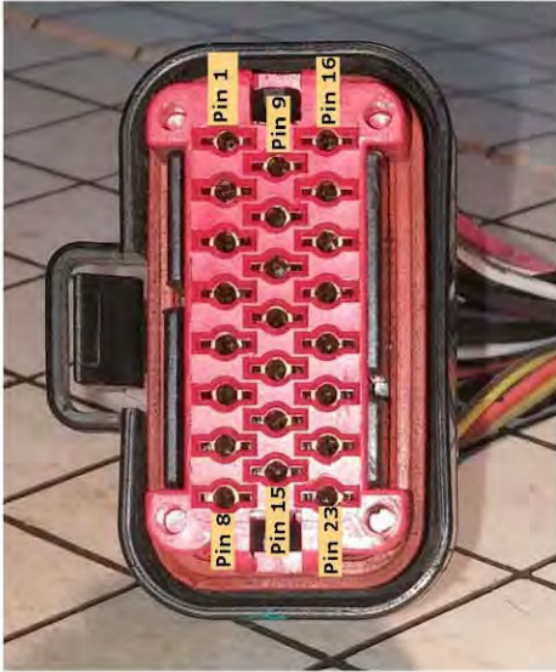

Cav	Col	Gauge
1	BN	1
2	DG/VT	0.5
3	WH/LG	0.5
4	PK/WH	0.5
5	LB/WH	0.5
6	OG/VT	0.5
7	YE/GY	0.5
8	YE/BN	0.5
9	RD	0.5
10	WH	0.5
11	BK	1
12	WH/LB	0.5
13	BN/OG	0.5
14	VT/LB	0.5
15	LG	0.5
16	DG	0.5
17	BK	0.5
18	SH	4.01
19	LG/RD	0.5
20	LG/DB	0.5
21	WH/BK	0.5
22	BN/YE	0.5

PIN NUMBER	Application
1	Key Power
2	BRAKE ON
3	BRAKE OFF
4	CAN HIGH IN +
5	CAN LOW IN -
6	NOT USED
7	NOT USED
8	NOT USED
9	ENCODER REF
10	ENCODER A
11	GROUND
12	ACCEL REF 1
13	ACCEL SIG 1
14	ACCEL SIG 2
15	ACCEL 1 SIG RTN
16	ENCODER B
17	ENCODER RETURN
18	ENCODER SHIELD -
19	CAN HIGH OUT
20	CAN LOW OUT
21	ACCEL REF 2
22	ACCEL SIG RTN

Pin Identification and Connection Points For Small "D" Motor

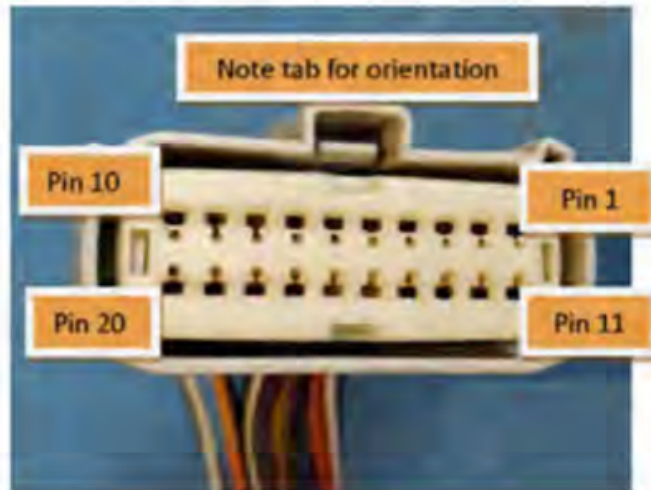

Inverter Pin Number	Wire Color	Controller Connection
1	Red	Can Low to Controller terminal J3
2	White Red	Can High to Controller terminal K3
3	Yellow and Green	Not Used
4	Dark Blue	Accelerator Signal Voltage Accelerator Pin 2
5	White/Blue	Accelerator Reference Voltage Accelerator Pin 1
6	Brown/Yellow	Accelerator Signal Return 1 Accelerator Pin 4
7	Light Green	Accelerator Signal Return 2 Accelerator Pin 3
8	Empty	
9	Empty	
10	Brown	Inverter 12V Power from Controller Terminal E1
11	Yellow/Red	Not used
12	Violet/Light Blue	Accelerator Signal Voltage 2 to Accelerator Pin 5
13	Brown	Ignition switch power to controller terminal E3
14	White/Black	Accelerator Reference Voltage 2 to accelerator Pin 6
15	Empty	
16	Empty	
17	Dark Green/Violet	Brake On – Brake Switch Pin 4
18	Orange/ Violet	Charge Proximity – Ground to enable Drive
19	Black	Chassis Ground
20	White/Dark Green	Brake Off – Brake Switch Pin 3

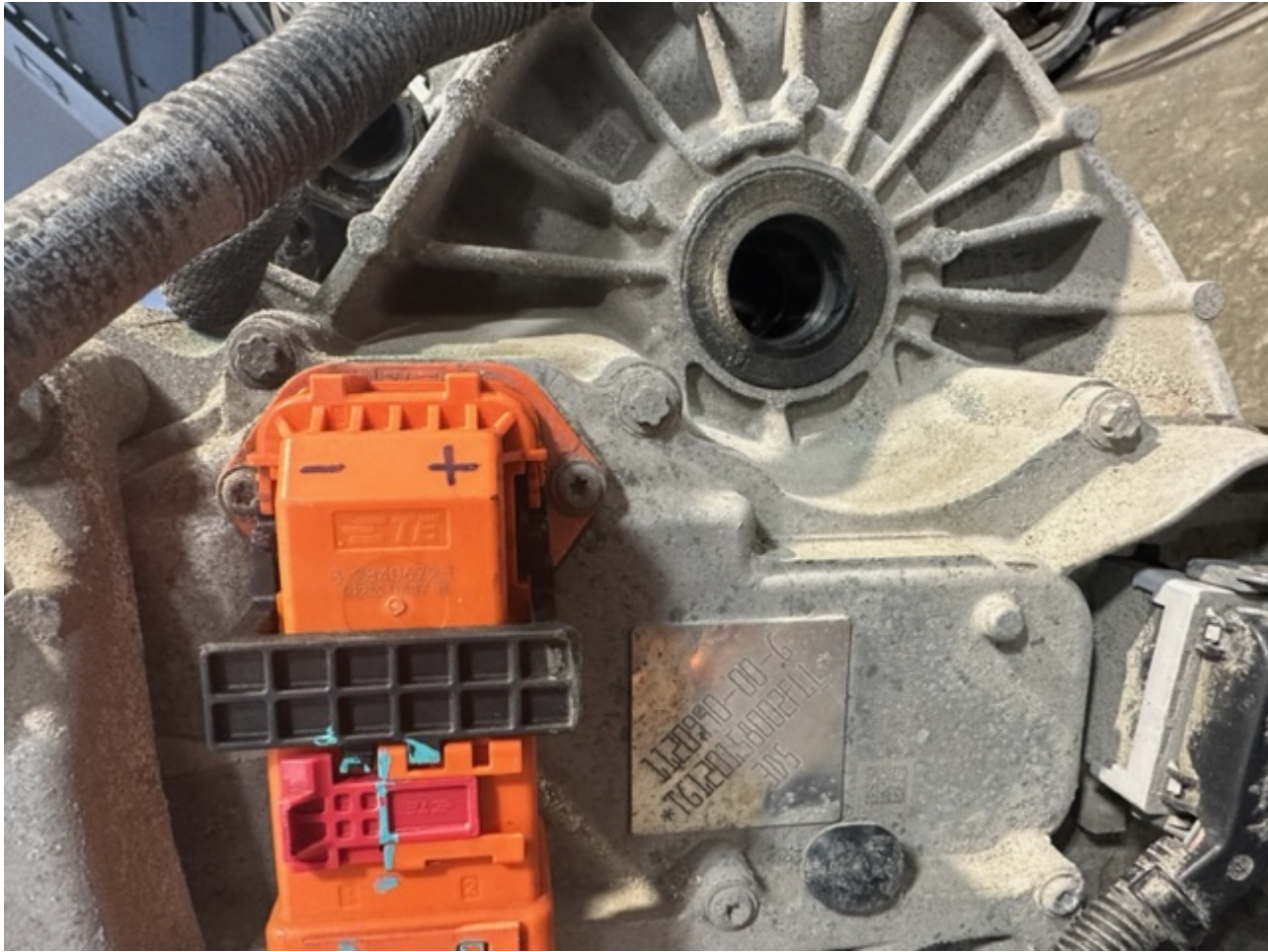

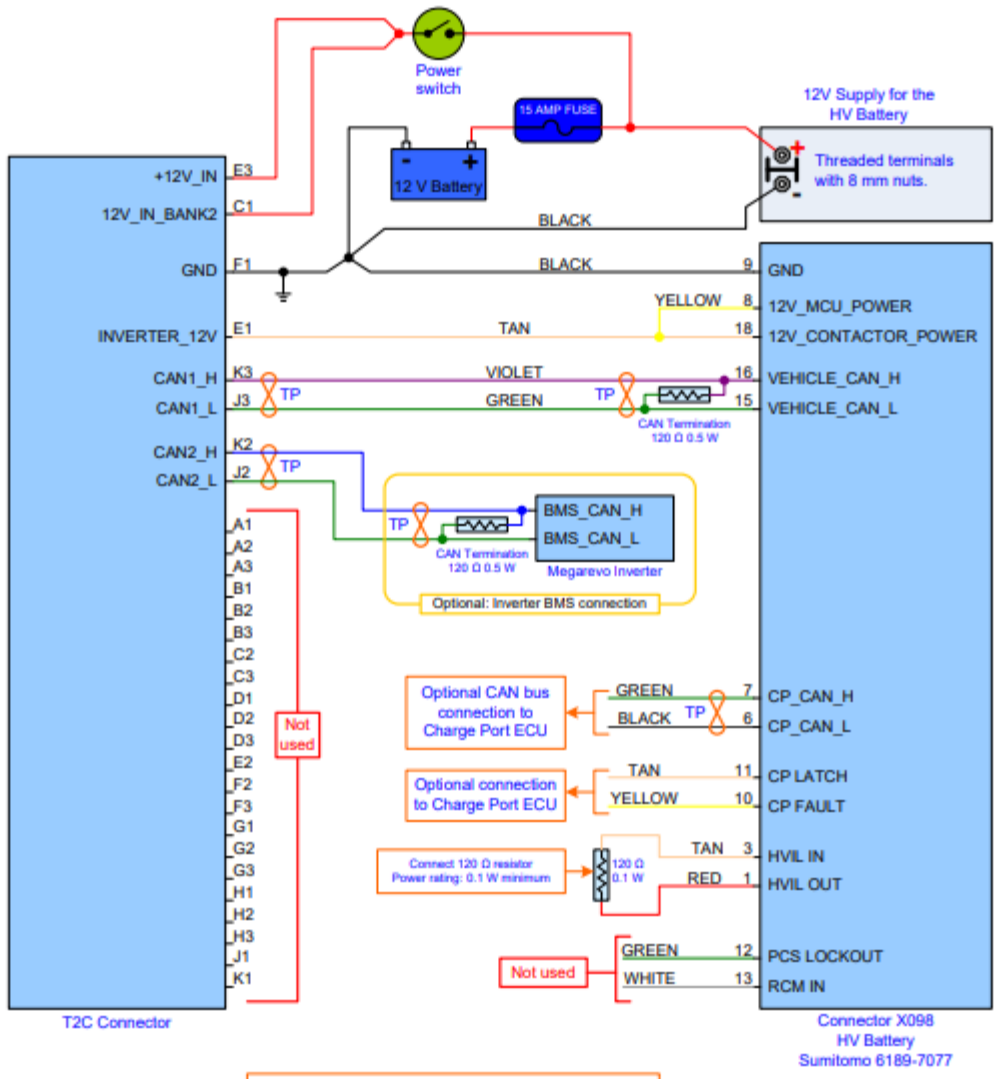

Legend
 TP = Twisted pair

Notes:
 1. Always refer to the pin numbers shown above to determine the signal location. The wire colors indicated above are for convenience only and they may not match all versions of the wiring harness that are available.

Wiring diagram: Model 3 Battery Pack

Troubleshooting

Here we will list some problems and solutions for issues we have seen users have over the past years.

Brake switch; If you have a situation where you cannot engage drive or reverse, the most common cause is the brake switch being wired incorrectly.

The brake switch circuit is not a simple on/off circuit, but instead switches power or ground between two pins (depending on the drive unit used). You can use the main screen of the dash app to monitor for correct brake switch operation. The "brake/regen" near the top center should turn red when the brake is depressed, and be grey otherwise. You will not be able to engage any drive gears until this is working correctly.

We recommend using the Tesla brake switch to avoid problems with this.

Accelerator pedal; There have been a few cases where customers have wired this incorrectly. In these cases you will get fault codes for this. Using the Tesla harness pigtails on the pedal and inverter will help avoid problems here.

Encoder wiring; customers who make their own inverter wiring harness have had trouble with this, pay attention to pin numbers and not the order of the wires if you have trouble with this. You will get fault codes for the encoder if you get this wrong. Using the Tesla harness will help avoid these sort of issues.

Shift inputs (or other inputs) grounded; The shift inputs are momentary inputs in the earlier firmware versions. Keeping them permanently grounded will interfere with the T2C boot sequence if you are running an earlier version of the T2C firmware.

CAN issues; CAN bus communications are very robust, but there are still some points you need to consider;

-All CAN wiring should be twisted pair, and should be routed as far from HV cabling as possible.

-There should be exactly two 120 ohm CAN termination resistors on any CAN bus. There is one in the T2C, and the other should be installed as per the manual on LDU applications. Model 3 drive units have an internal resistor.

Other CAN hardware on the T2C bus;

-If you have problems that may be related to CAN communications, the first thing we will tell you to do is disconnect all other CAN hardware you have connected to the bus (besides the T2C and inverter). So you may as well do this yourself before contacting us if you are having problems. There have been cases where aftermarket BMS, gauges or other hardware cause problems when connected to the same bus as the inverter and T2C.

Any other hardware you connect to the same bus should not have any termination resistors installed or enabled. Also, you should understand that if the other hardware is broadcasting messages on the bus, there may be a conflict with CAN ID's that the inverter or T2C is broadcasting or listening for. So these are potential sources of trouble. Best to put other CAN hardware on it's own bus unless you have a good reason to do otherwise.

HV isolation;

-This is an area where some customers have had problems. Poor HV isolation can cause problems with CAN communications, damage hardware, and of course be dangerous to your health. We have had cases where customers have blown up controllers and Tesla inverter control boards due to issues with poor isolation between the HV circuit and the chassis. Make sure you have done a good job isolating your HV circuit from the rest of the vehicle.

Testing the drive system "on the bench";

Many customers want to "test" their drive system while it is out of the vehicle. This is understandable, but the amount of useful testing that can be done with a drive unit on the shop floor with no axles/wheels/vehicle attached is limited, and you will not be able to determine much beyond confirming it goes into drive and reverse.

We have had customers contact us after the drive system does not behave the way they expect when they put it in drive and floor the accelerator without any driveline attached.

In particular, the Model 3/Y drive units and dual motor powertrains will detect that there is no vehicle attached pretty quickly, so restrict your testing to the basics until the drive system is installed in a vehicle.

GNSS Traction control unit

We now offer traction control for supported drive units. This requires our GNSS traction control module, which is available for sale on the EV-controls website.

Tesla large drive units and Model 3 and Y rear drive units are supported at the moment.

This module produces a high resolution vehicle speed signal, which the T2C uses to determine wheel slippage of the driven wheels. The T2C then calculates and applies the required torque adjustment to maintain optimum traction. This all happens on a millisecond level, and results in optimal traction for the current conditions.

To use the traction control features, you should wire the GNSS unit as per the pinout diagram elsewhere in this guide, connecting 12V ignition power, Ground, and CAN high and low to the CAN 1 bus on the T2C. You can also connect the 12V backup power directly to the battery. (it only draws 0.4 milliamps) This will allow the GNSS unit to remember the last satellite fix, and will result in a reduced time before traction control is available each time you start the vehicle.

The traction control module can be mounted anywhere in the vehicle, the GPS antenna must have a clear view of the sky. We have had good results mounting the antenna on the dash of our test vehicles, pointing up through the windshield.

Once the T2C sees the GNSS unit online with a reliable speed signal and satellite fix, you will see a green "TC on" indication in the dash app at the top of the power gauge.

You can turn the traction control off and on using the button at the bottom right of the dash app. You can also turn the traction control off by shutting off power to the GNSS module.

When the traction control is off or not available, you will see a red "No TC" indication at the top of the power gauge in the dash app.

The only parameter you will need to set in order for the traction control to operate correctly is the "Front WSS" value in the T2C settings page.

This value compensates for wheel and tire diameter, and corrects the error between actual vehicle speed, and the road speed the T2C calculates from motor RPM.

When the "Front WSS" value is set correctly, you will see the "TC_SlipMeasured" parameter displayed on the main screen of the dash app hover around zero when the vehicle is driven in a straight line at a steady speed under no wheelspin conditions. It is normal for the "TC_SlipMeasured" value to switch back and forth between slightly positive and negative values under these conditions.

(it will never sit exactly at zero). Start with a value of 128, and adjust from there. You can do this while driving, by going to the settings page in the dash app, setting the front WSS value, writing the settings, and then checking the TC_SlipMeasured value on the main screen. You can also use the logging features of course.

We added a button in the settings page to automatically calibrate the scalar in the latest release. To use this feature, drive the car on a straight section of road with a good GPS signal (TC on illuminated in green) and tap the yellow button at the right side of the row of buttons. The T2C firmware will calculate the correct scalar and write it to the settings.



CAN control of power and regen (typical use is derating by BMS)

The current firmware allows users to set power and regen limits in kW over CAN.

We can supply a .dbc file that describes the format, and we have included some examples below.

You must use the format defined below, and you cannot broadcast any CAN data on the T2C bus other than the ID's specified below.

The CAN node you use to transmit should have any termination resistor disabled. Baud rate is 500kbs.

There is no frequency check enforced, but we would recommend 500ms.

The power limits sent over CAN on ID 0x696 will override the power limits set in the T2C settings. If no messages are received, the T2C defaults to the power limits set in the dash app settings.

On reboot, the T2C will also default to these settings.

We cannot troubleshoot problems caused by connecting any other CAN nodes to the bus.

We have tested the functionality here and can confirm it works as expected if the details outlined above are respected.

The examples below are to demonstrate the format.

The first 16 bits (big endian) is power limit in kW, factor is 0.01

The second 16 bits (big endian) is regen limit in kW, factor is 0.01

ID: 0x696 Std Bus: 0 Len: 8

Data Bytes: 0x1A 0xF4 0xA4 0x20 0x00 0x00 0x00 0x00

BMS_maxDischargePower: 420.16kW

BMS_maxRegenPower: 69kW

ID: 0x696 Std Bus: 0 Len: 8

Data Bytes: 0xA4 0x10 0x1A 0xF4 0x00 0x00 0x00 0x00

BMS_maxDischargePower: 69kW

BMS_maxRegenPower: 420kW

CAN control of shift functions

The current firmware allows users to control drive modes (Drive, neutral and reverse) over CAN.

We can supply a .dbc file that describes the format, and we have included some examples below.

You must use the format defined below, and you cannot broadcast any CAN data on the T2C bus other than the ID's specified below.

The CAN node you use to transmit should have any termination resistor disabled. Baud rate is 500kbs, and 11 bit ID 0x697 is used for shift commands.

Sending a single frame should trigger the drive mode change, but you could also send a small series of 4 for example.

We cannot troubleshoot problems caused by connecting any other CAN nodes to the bus.

We have tested the functionality here and can confirm it works as expected if the details outlined above are respected.

The first byte (8 bits) is what changes in the shift command message, the next 16 bits are used as an extra check by the T2C firmware.

ID: 0x697 Std Bus: 0 Len: 8

Data Bytes: 0x0D 0xBE 0xEF 0x00 0x00 0x00 0x00 0x00

ShiftCommand: DRIVE_SHIFT_COMMAND

ID: 0x697 Std Bus: 0 Len: 8

Data Bytes: 0x0E 0xBE 0xEF 0x00 0x00 0x00 0x00 0x00

ShiftCommand: NEUTRAL_SHIFT_COMMAND

ID: 0x697 Std Bus: 0 Len: 8

Data Bytes: 0x0F 0xBE 0xEF 0x00 0x00 0x00 0x00 0x00

ShiftCommand: REVERSE_SHIFT_COMMAND

