

## Model S Rear Coil-Over Bracket Kit

Part Number HEV001-001

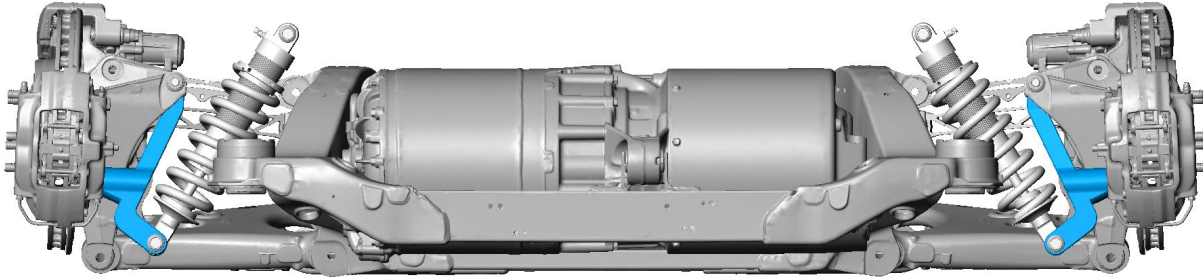

**\*Compatible with 2012-2021 Tesla Model S Rear Knuckles (Tesla PN 1042506-00-B and 1042507-00-B).**

This kit relocates the stock mounting location of the coil over shocks on the rear of the Model S suspension approximately 9.75" lower and allows for the use of widely available aftermarket coil-over shocks on swap applications where space constraints are an issue. Brackets are constructed from billet aluminum to provide a rigid mount for coil over shocks. The finish is bead blasted and clear powder coated to seamlessly blend in with the stock Tesla suspension components for a stealthy O.E. look.

*Note: **NOT COMPATIBLE WITH STOCK TESLA COIL OVER SHOCKS.** The recommended coil-over springs are standard dimension (2.5" inside dimension x 12" length). As these brackets are not swap vehicle specific it is left up to the consumer to determine the spring rate needed for the particular vehicle geometry and the front to rear weight balance of the vehicle. This kit locates the lower shock mount but will be necessary for the consumer to fabricate upper coil over mounts to locate the upper end of the shock. The lower attachment style of the shock should be an eyelet bushing type that is 5/8" or narrower and is fastened using a 1/2" bolt. This kit will also require custom brake lines as the factory Tesla lines will interfere with the fitment of the brackets.*

### Included Components:

- (1) LH Lower Coil Over Shock Bracket
- (1) RH Lower Coil Over Shock Bracket
- (2) M14 x 2.0 x 90mm Flange Head Bolt
- (2) M14 x 2.0 Flange Head Nylon Lock Nut
- (2) M12 x1.75 x 100mm Flange Head Bolt
- (4) 1/2"-13 x 2.25" Flange Head Bolt
- (4) 1/2"-13 Flange Head Nylon Lock Nut
- (4) 1/2" Washers

## Installation

1. Remove factory Tesla brake lines and lower brake caliper mounting bolts from both sides.
2. If still installed remove both factory Tesla coil over assemblies from suspension knuckles.
3. On the LH side install a M14 x 90mm flange head bolt and lock nut through the factory tabs on the knuckle passing through the upper hole on the coil over relocation bracket as shown in the image below. Do not fully torque the fastener at this time. It is necessary to install the bolt in the direction shown in order to maintain clearance to the factory suspension linkage located nearby.

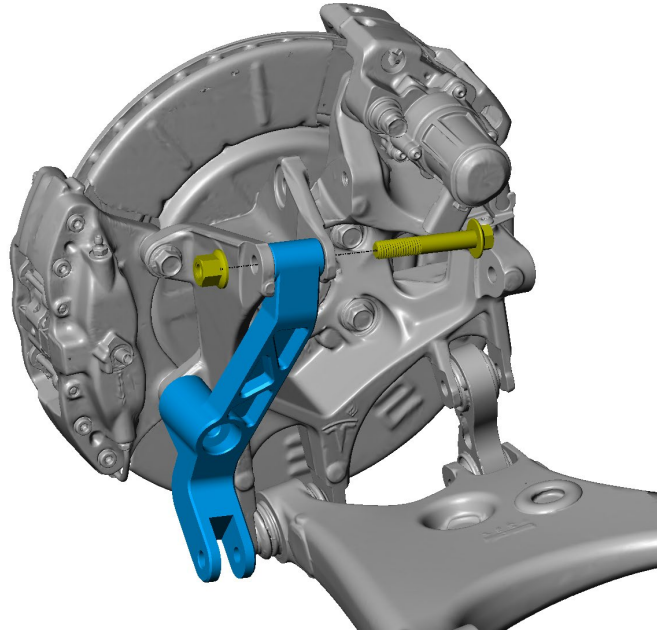

4. Install a M12 x 100mm flange head bolt through the bore in the coil over bracket as shown below and thread into the lower brake caliper hole. Torque bolt to 75 Ft-lbs.

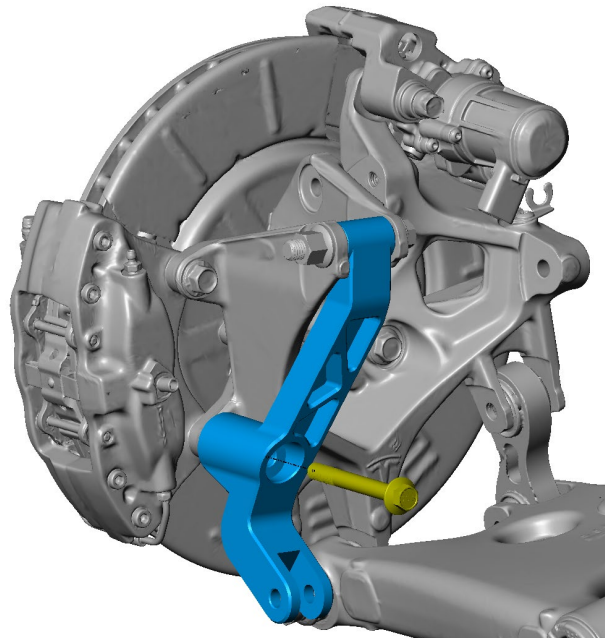

5. Torque M14 fastener from step 3 to 85 Ft-lbs.
6. Install coil over shock assembly as shown in the image below. Be sure to install the two small washers on either side of the shock between the eyelet and bracket body. If using a narrower shock end be sure to install extra washers to take up any side to side movement as this movement could cause damage to the bracket or shock body. The 1/2" flange bolt should be installed with the nut toward the lower control arm. Install hand tight for now.

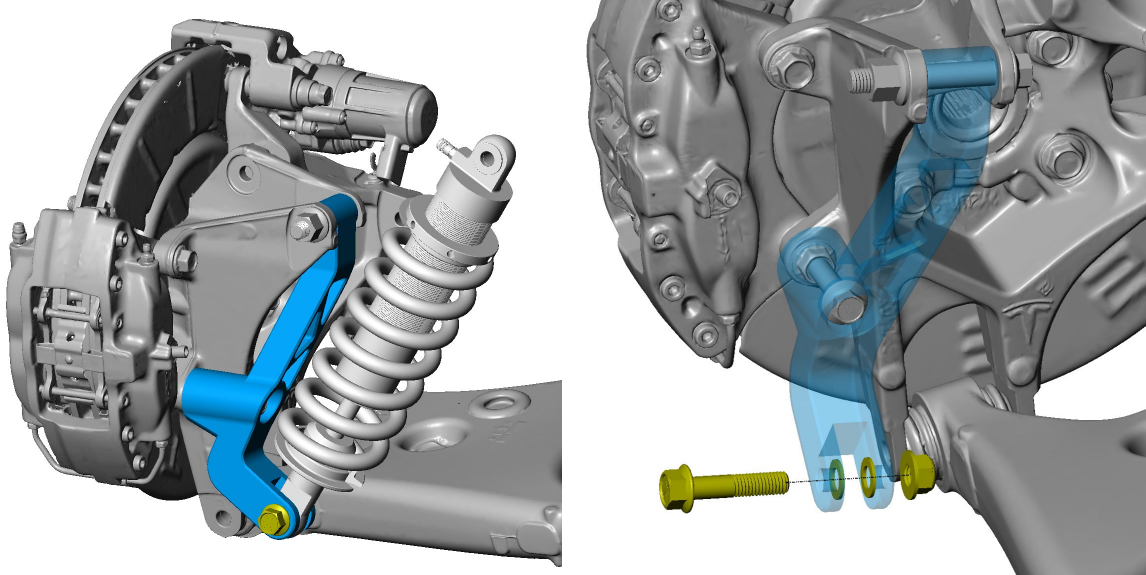

7. After the upper shock bolt is installed in user fabricated upper bracket (as in example photo below) both shock bolts can be torqued to 60 Ft-lbs.

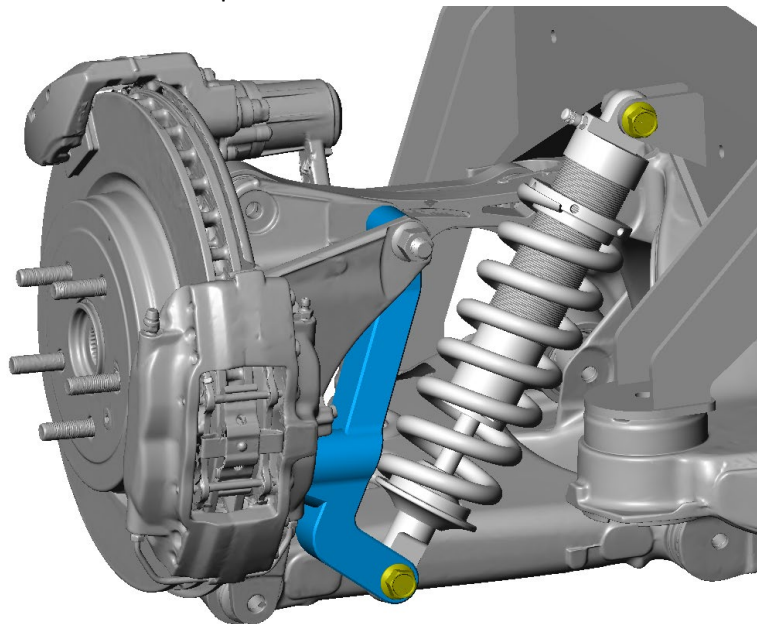

8. Repeat steps 3-7 on the RH side of suspension.
9. After the vehicle suspension is fully loaded under its own weight all hardware should be retorqued with the above values.